

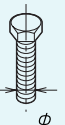

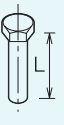
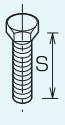
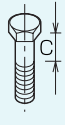
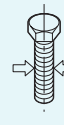

Roll highly accurate and precise screws for watches and other micro applications

THI-2MR

MICRO ROLLING MACHINE

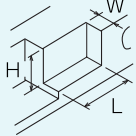
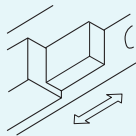
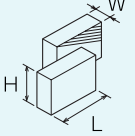
Threads without points				Threads pressure	Power	Speeds	Standard die pockets	Standard stroke	Standard die	Weight (net)	Coolant (litros)
Max	Max	Max	Max								
						RPM 					
M1.2	10	10	0	250kg	4P 0.4kW	200 S 400	L W H 30×14×15 65×14×15	100/120	L W H 30×14×15 65×14×15	0.5ton	4 ℓ

- The supply chute and sliding surface are finished with a high precision to ensure product quality.
- The die block can be adjusted back and forth with a tapered wedge and push-bolt combination, making it easy to finely adjust the die set.
- The standard dial gauge is perfect for fine adjustments.
- Safety devices, such as a full-face safety cover and opening interlock, are provided.



Outline dimensions

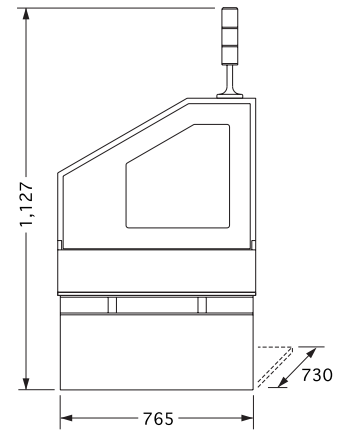

Dual-starter method

- Highly precise threads can be efficiently rolled at a high speed with the dual-starter methods.

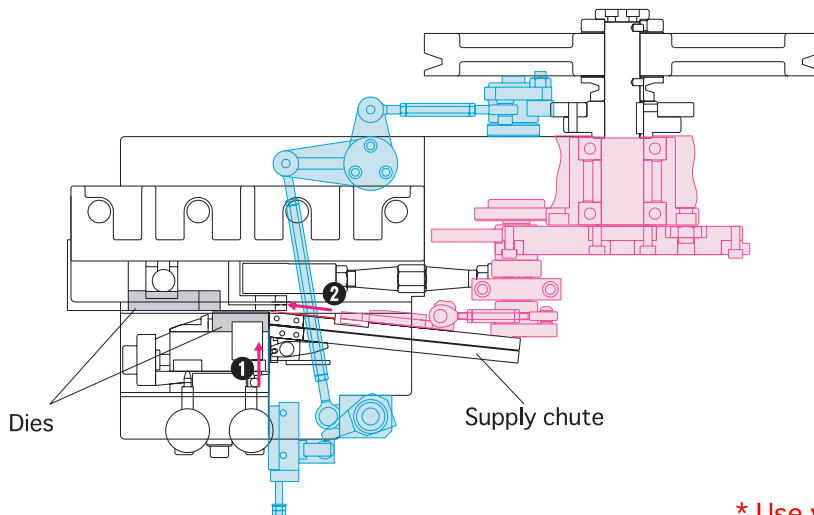

* Use your browser's Print button to print this page.