

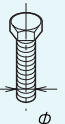

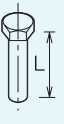
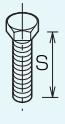
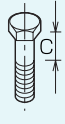
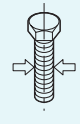

Compact high performance machine suitable even for special blank machining

THI-4R

THREAD ROLLING MACHINE

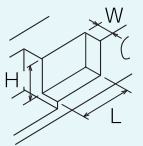
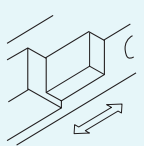
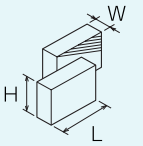
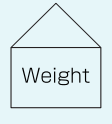
Threads without points				Threads pressure	Power	Speeds	Standard die pockets	Standard stroke	Standard die	Weight (net)	Coolant (litros)
Max	Max	Max	Max								
						RPM 					
M4	40	25	15	1,650kg	4P 2.2kW	130 S 350	L W H 62×20×40 95×20×40	140	L W H 60×20×25 70×20×25	0.7ton	15ℓ

- This high performance compact high-speed rolling machine can handle blanks smaller than M4.
- This compact machine has a one-rank higher rigidity and is perfect even for machining special blanks.
- This machine can be applied for a wide range from M1.7 to M4.
- Our originally developed supply method makes it possible to automatically roll even special blanks.

The methods that we have originally developed can also be used to automatically roll headless blanks, such as stud bolts or shaft shapes, etc. (This mechanism can be incorporated in other brands of rolling machines.) Of course, standard straight rolling with a part feeder supply is possible, and this machine can be docked with an automatic washer assembly machine such as the AV.



Outline dimensions

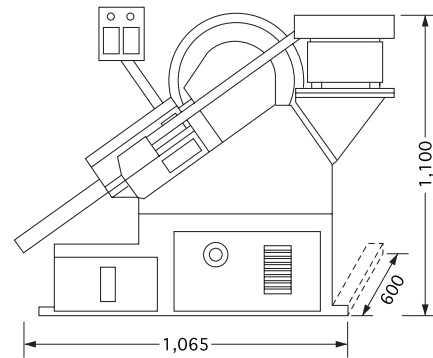

Example of machining headless workpiece

1. Simultaneous rolling of knurl and screw

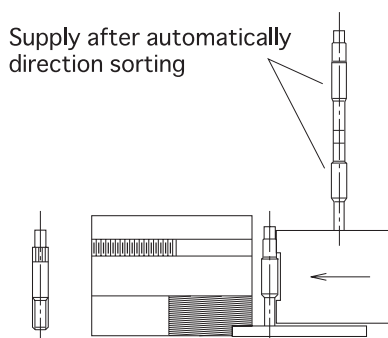

2. Simultaneous rolling of screws (stud bolts, etc.)

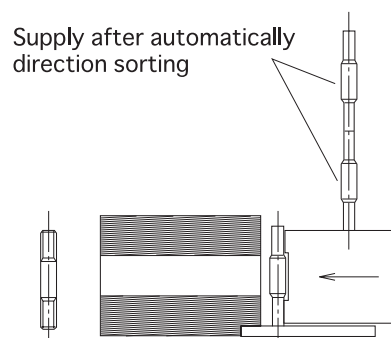

* Use your browser's Print button to print this page.